

FEATURES:

- Blow-out Proof Stem
- Pressure Balance Hole in Ball Slot
- Full Port
- Various Thread Standards Available
- Casting Approved by TÜV AD 2000-Merkblatt W0

STANDARDS:

- Design : MSS SP-110
- Wall Thickness : EN 12516-3
- Pipe Thread : ASME B1.20.1
DIN 2999 / 259, ISO 228 / 1
JIS B 0203, ISO 7 / 1
- Inspection & Testing : MSS SP-110

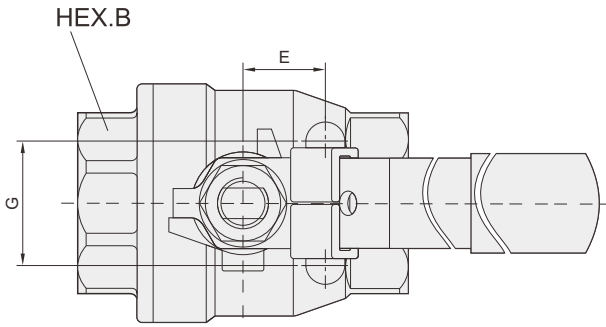

SIZE: 1/4" ~ 2"

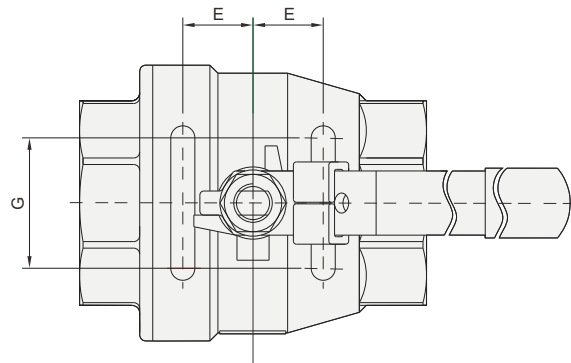

2-1/2" ~ 3"

NO.	PART NAME	MATERIALS		
1	Body	CF8M	CF8	WCB
2	Cap	CF8M	CF8	WCB
3	Ball	CF8M	CF8	
4	Ball Seat	PTFE		
5	Stem	SUS 316	SUS 304	
6	Thrust Washer	PTFE		
7	V-Ring Packing	PTFE		
8	Gland Nut	SUS 304		
9	Stem Washer	SUS 304		
10	Stem Nut	A194 - 8		
11	Handle	SUS 304		
12	Handle Sleeve	Vinyl plastic		
13	Locking Device	SUS 304		
14	Body Gasket	PTFE		

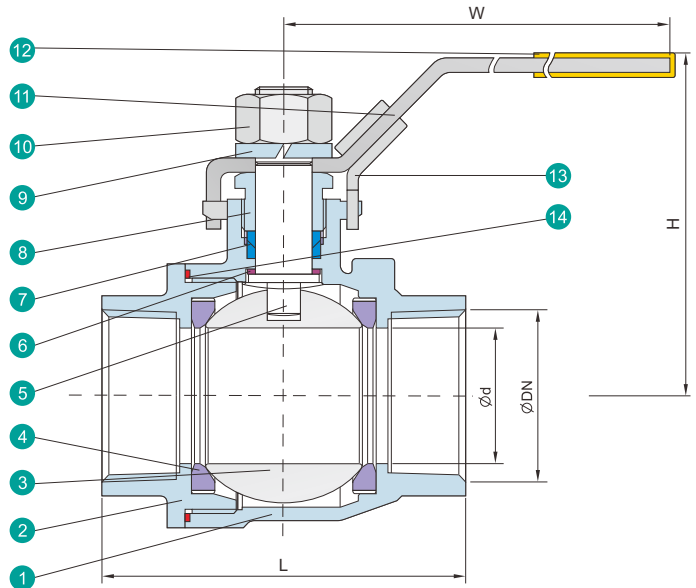

SIZE	d	L	H	W	E	G	HEX.B	Ø DN
1/4"	10.6	58.0	58.0	100.0	12.7	28.5	23.5	NPT
3/8"	12.0	58.0	58.0	100.0	12.7	28.5	23.5	
1/2"	15.0	62.0	58.0	100.0	12.7	28.5	25.0	
3/4"	20.0	72.4	64.0	129.0	22.0	34.8	32.0	BSP
1"	25.0	85.0	77.0	156.0	22.0	34.8	41.0	PT
1-1/4"	32.0	94.0	83.0	156.0	23.6	38.1	50.0	DIN
1-1/2"	38.0	105.0	96.0	182.5	23.6	38.1	56.0	
2"	50.0	125.0	102.0	182.5	23.6	38.1	70.0	
2-1/2"	63.5	155.0	129.0	252.0	35.0	65.0	83.0	etc...
3"	76.0	173.0	138.5	252.0	35.0	65.0	102.0	

Unit : mm