

1000 PSI

3-PC Body, Welding Ends, Full Port

KV-C31

Applicable Standards:

- Design: ASME B 16.34, BS 6364
- Face to Face: DIN 3202 S13
- Welding ends: ASME B 16.25
- Wall Thickness: ASME B 16.34
- Inspection & Testing: API 598, BS 6364
- Temperature: -196°C ≤ T ≤ +150°C

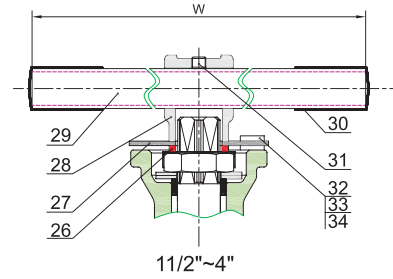

No.	Parts Name	Material
1	Body	CF8M CF8
2	Cap	CF8M CF8
3	Ball	CF8M CF8
4	Ball Seats	PCTFE
5	Stem	F316 F304
6	Stem Sleeve	50%SS+50%PTFE
7	Stem Packing	TFM1600/316 Spiral Wound + Grafoil*
8	Bolt	A320-B8
9	Hex. Nuts	A194-8
10	Bushing	SUS304
11	Extention Bonnet	F316 F304
12	L Type Sleeve	50%SS+50%PTFE
13	Stem Packing	TFM1600/Grafoil*
14	Bushing	SUS304
15	Gland	SUS316 SUS304
16	Belleville Washer	SUS301
17	Stem Nuts	A194-8
18	Lever(DN15~DN32)	CF8
19	Lever Nut(DN15~DN32)	A194-8
20	Stem Bushing	SUS304
21	Anti-Static Device	SUS304
22	Body Gasket	TFM1600/316 Spiral Wound + Grafoil*
23	Bolt	A320-B8
24	Hex. Nut	A194-8
25	Bushing	SUS304
26	Square slot bushing (DN40~DN100)	SUS304
27	Stop-lock Cap(DN40~DN100)	SUS420
28	Handle Adaptor(DN40~DN100)	CF8
29	Pipe Handle(DN40~DN100)	A53+Zn Plated
30	Lever Sleeve(DN40~DN100)	VINYL PLASTIC
31	Set screw (DN40~DN100)	SUS304
32	Stop Bolt (DN40~DN100)	SUS304
33	Hex Nut (DN40~DN100)	A194-8
34	Bushing(DN40~DN100)	SUS304

*Materials for Fire-Safe Type

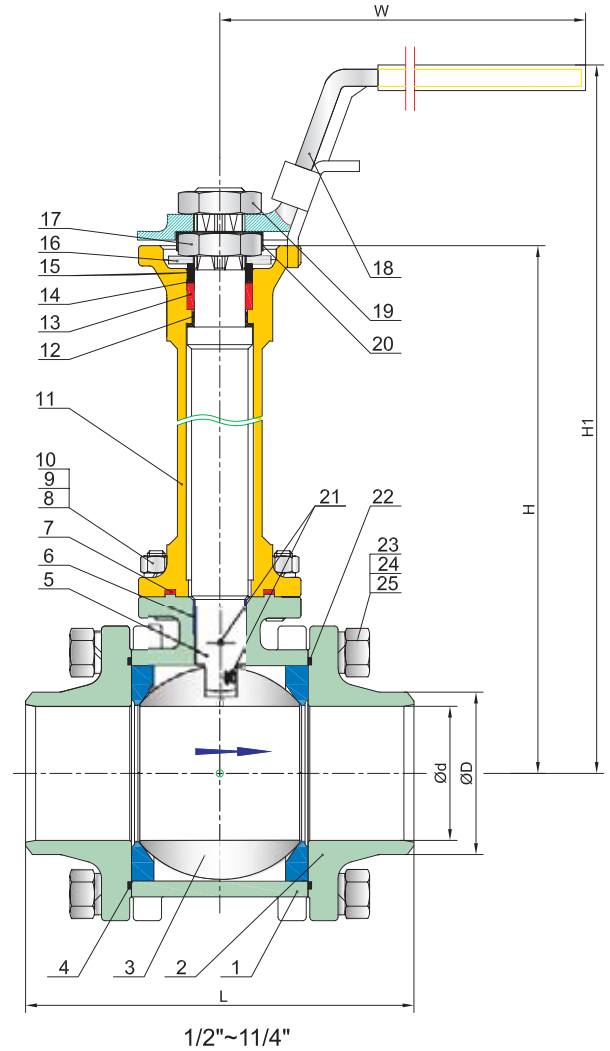

Unit:mm

SIZE	SIZE	φd	ΦD	L	W	H	H1	ISO 5211
DN15	1/2"	15	22	140	175	290	322	F05
DN20	3/4"	20	28	152	175	293	325	F05
DN25	1"	25	34	165	190	318	350	F07
DN32	1-1/4"	32	43	178	190	323	355	F07
DN40	1-1/2"	38	50	190	300	365	393	F10
DN50	2"	50	61	216	300	372	400	F10
DN65	2-1/2"	63.5	76	241	400	457	492	F10
DN80	3"	76	92	282	400	465	500	F10
DN100	4"	100	115	305	600	580	650	F12